

HANDICRAFT wood design V1.0



HANDICRAFT

ul. Binino 70
64-560 Ostroróg
+48 516 765 989



Fundusze
Europejskie
Wiedza Edukacja Rozwój



Polska

Unia Europejska
Europejski Fundusz Społeczny



www.handiraft.com.pl



2 Men Männer

Our adventure with wood began in the 80s, when the basic materials were hard to reach. My parents were left alone with the production. The furniture in our family house was mostly wooden. Everything was made by my father and my grandfather. For me as a young boy it was a huge inspiration. My father was an authority for me – I have always dreamt of being like him. I accompanied him willingly and helped him in all the works. Thanks to him I gained knowledge and experience. Many years of observations have allowed me to work with solid wood on my own. My dream became the desire to start my own business. My dad and I run a small workshop that is constantly developing and takes care of familiar atmosphere in the company at the same time. Our products are our history

Unsere Geschichte beginnt in den 80er Jahren, zu einer Zeit wo herkömmliche Produkte schwer zu bekommen waren. Meine Eltern mussten auf eigene Faust handeln. Unser Familienhaus war mehrheitlich aus Holz errichtet worden. Alles in Handwerksarbeit von meinem Vater in Zusammenarbeit mit meinem Großvater. Für einen kleinen Jungen wie mich war das eine enorme Inspiration. Mein Vater war mein Vorbild und ich wollte immer so sein wie er. Ich war stets bemüht ihm zu helfen, wodurch ich das Wissen und die Erfahrung sammeln konnte. Jahrelanges beobachten verhalf mir dabei eigene Holzarbeiten mit Holzbohlen zu fertigen. Mein Traum war es selber was auf die Beine zu stellen. Zusammen mit meinem Vater leiten wir ein kleines Unternehmen welches sich stets weiterentwickelt und dabei seinen familiären Charakter nicht verliert. Wir achten dabei dass jedes unserer Produkte seine eigene Geschichte besitzt.



about us

Owing to our long-standing experience, tradition and craftsmanship the entire production process of our furniture is handmade. It allows to keep the individual characteristics of wood, its perfection and beauty. We make sure that all our products are distinguished by solidity and longevity, and we use completely natural and ecological oils to impregnate them.

Dank unserer langjährigen Erfahrung, Tradition und Handwerkskunst stellen wir unsere Möbel in eigener Handarbeit her, wodurch jede individuelle Charaktereigenschaft des Baumes erhalten bleibt. Das Holz verbindet Perfektion und Schönheit. Wir garantieren dass all unsere Produkte sich mit Beständigkeit und Resistenz auszeichnen. Zur Imprägnierung benutzen wir nur natürliche und ökologische Öle.

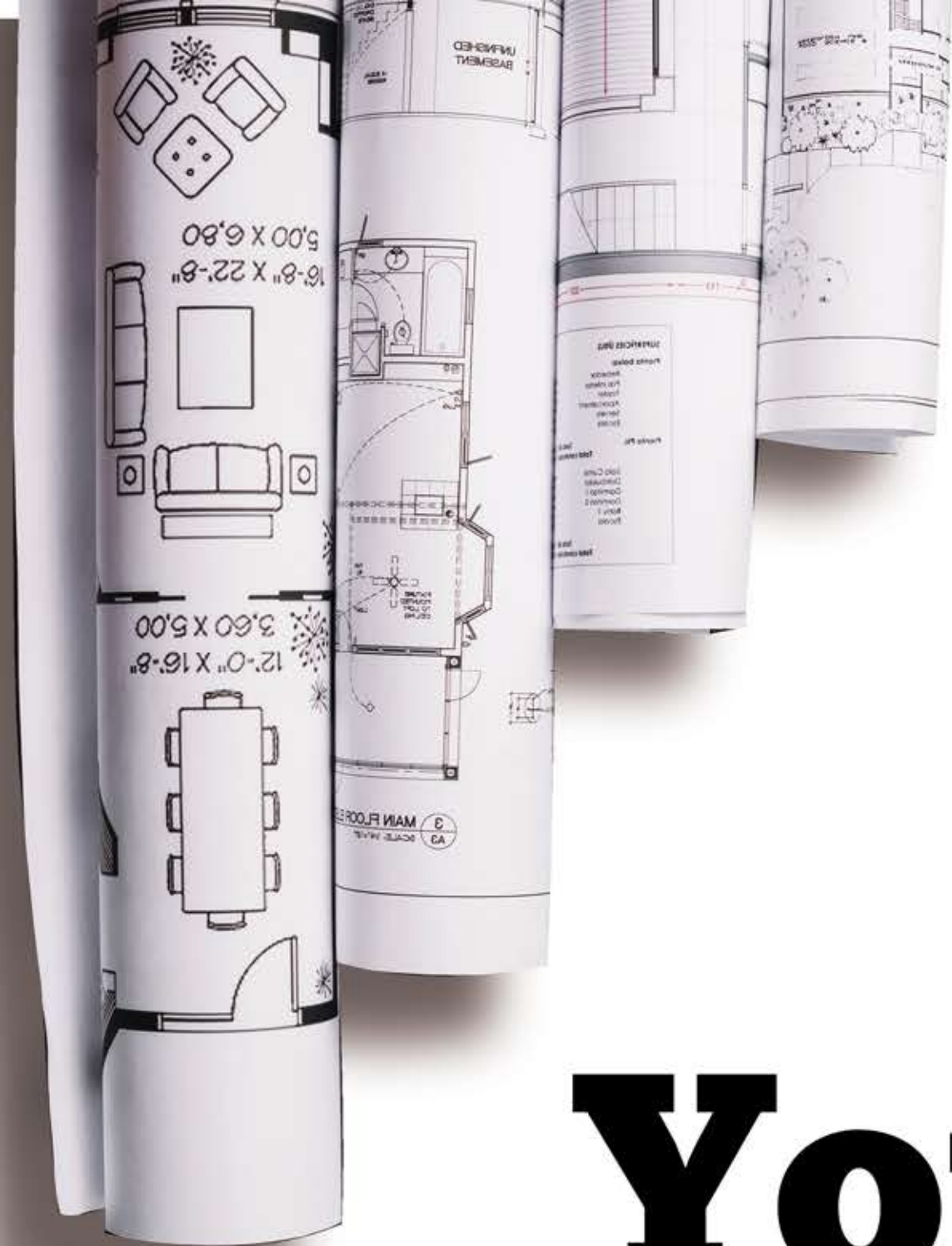

Your dreams in **our** hands



is a pseudo-Latin text used in web design, typography, layout, and printing in place of English to emphasise design elements over content. It's also called placeholder (or filler) text. It's a convenient tool for mock-ups. It helps to outline the visual elements of a document or presentation, eg typography, font, or layout. Lorem ipsum is mostly a part of a Latin text by the classical author and philosopher Cicero. Its words and letters have been changed by addition or removal, so to deliberately render its content nonsensical; it's not genuine, correct, or comprehensible Latin anymore. While lorem ipsum's still resembles classical Latin, it actually has no meaning whatsoever. As Cicero's text doesn't contain the letters K, W, or Z, alien to latin, these, and others are often inserted randomly to mimic the typographic appearance of European languages, as are digraphs not to be found in the original.

is a pseudo-Latin text used in web design, typography, layout, and printing in place of English to emphasise design elements over content. It's also called placeholder (or filler) text. It's a convenient tool for mock-ups. It helps to outline the visual elements of a document or presentation, eg typography, font, or layout. Lorem ipsum is mostly a part of a Latin text by the classical author and philosopher Cicero. Its words and letters have been changed by addition or removal, so to deliberately render its content nonsensical; it's not genuine, correct, or comprehensible Latin anymore. While lorem ipsum's still resembles classical Latin, it actually has no meaning whatsoever. As Cicero's text doesn't contain the letters K, W, or Z, alien to latin, these, and others are often inserted randomly to mimic the typographic appearance of European languages, as are digraphs not to be found in the original.

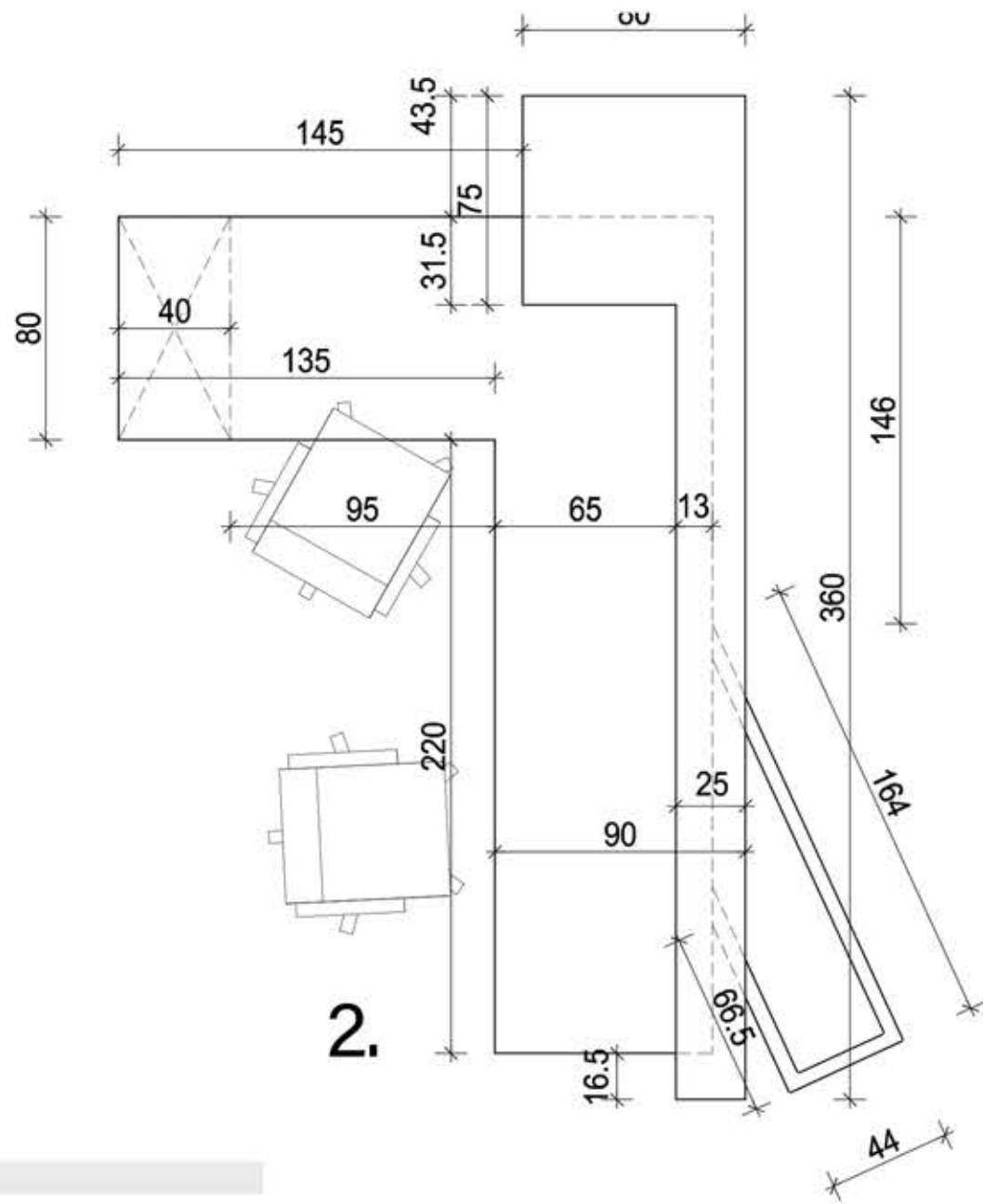
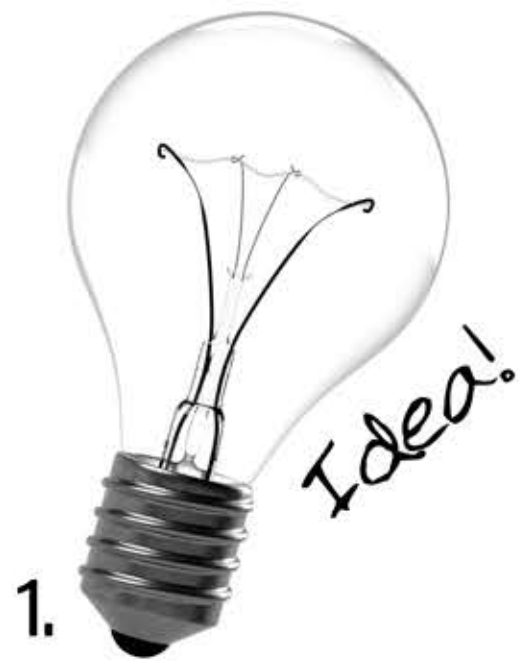

3.



autor projektu: Małgorzata Grzyb i Natalia Shyra (OMO)
realizacja: Małgorzata Grzyb

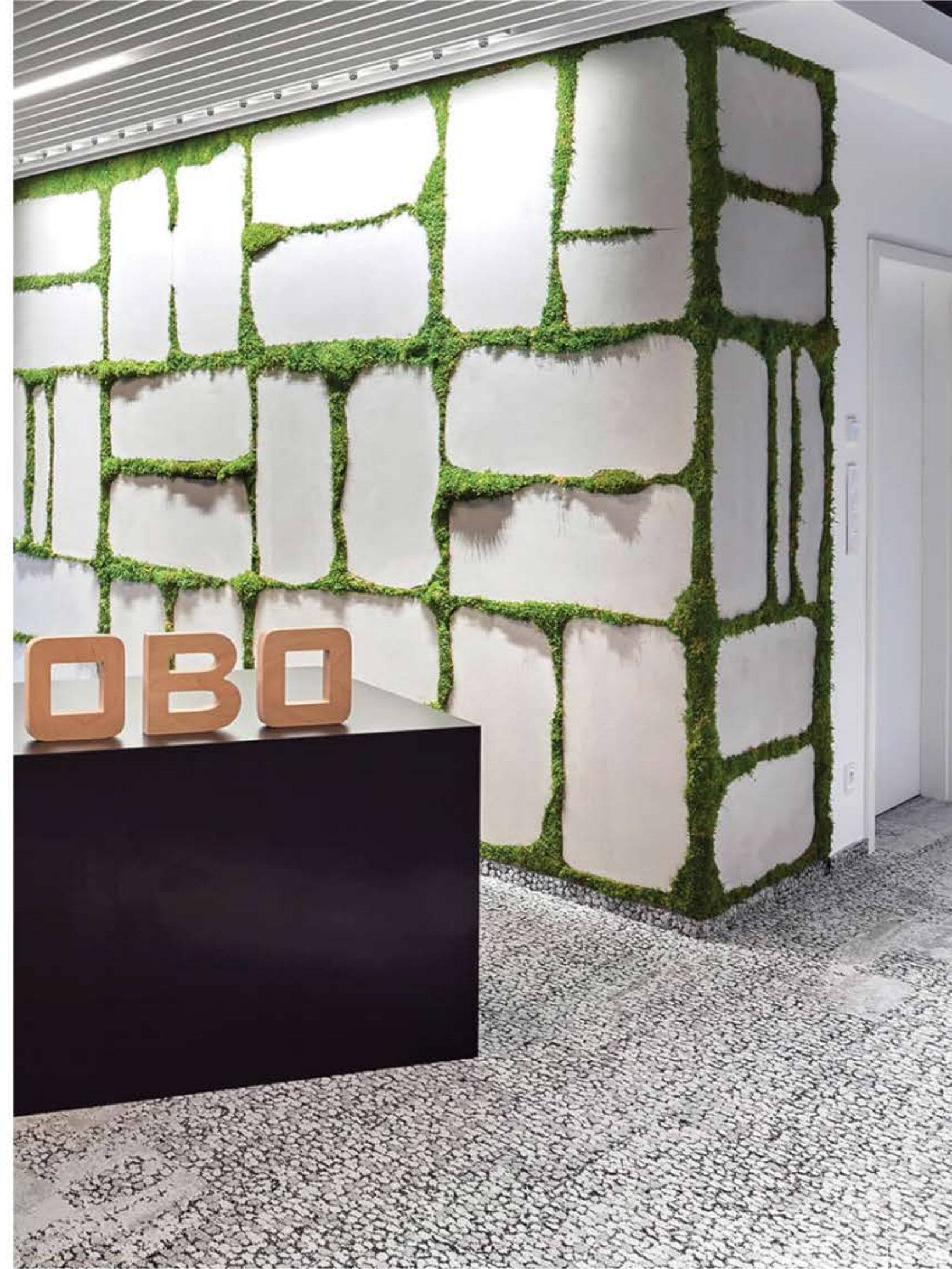

Graphic design

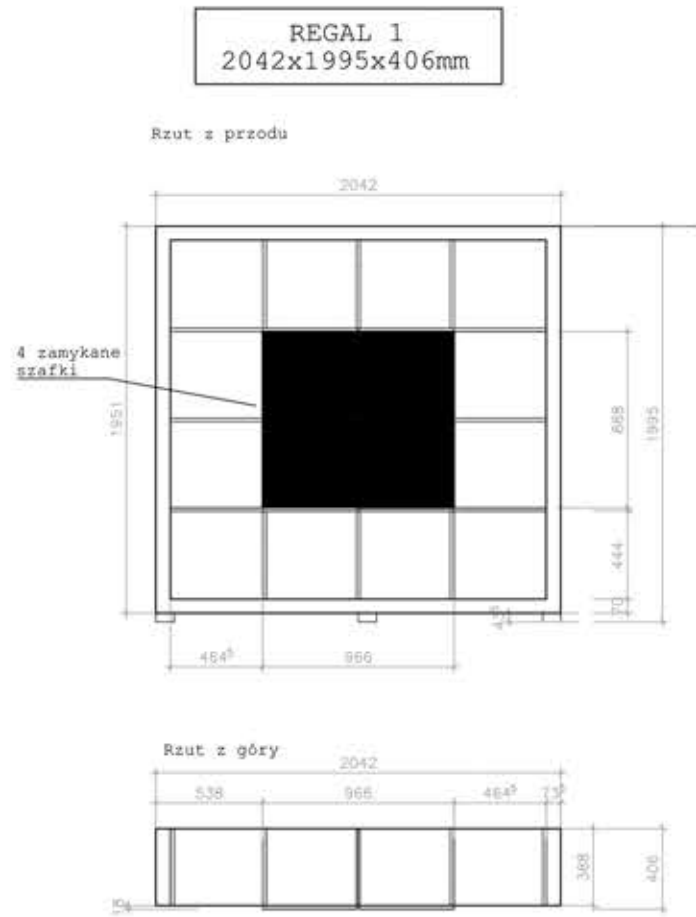

Project v2

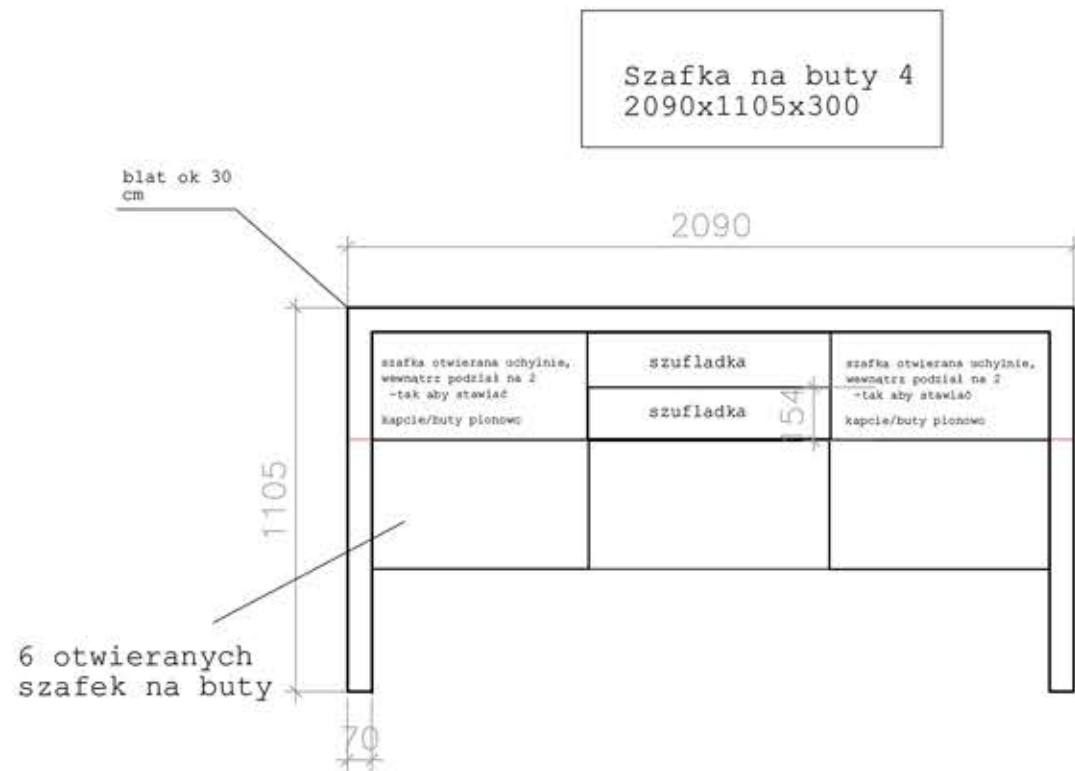



implementation



Lorem ipsum dolor sit amet, consectetur adipiscing elit, sed do eiusmod tempor incididunt ut labore et dolore magna aliqua. Ut enim ad minim veniam, quis nostrud exercitation ullamco laboris nisi ut aliquip ex ea commodo consequat. Duis aute irure dolor in reprehenderit in voluptate velit esse cillum dolore eu fugiat nulla pariatur. Excepte



Lorem ipsum dolor sit amet, consectetur adipiscing elit, sed do eiusmod tempor incididunt ut labore et dolore magna aliqua. Ut enim ad minim veniam, quis nostrud exercitation ullamco laboris nisi ut aliquip ex ea commodo consequat. Duis aute irure dolor in reprehenderit in voluptate velit esse cillum dolore eu fugiat nulla pariatur. Excepte



is a pseudo-Latin text used in web design, typography, layout, and printing in place of English to emphasise design elements over content. It's also called placeholder (or filler) text. It's a convenient tool for mock-ups. It helps to outline the visual elements of a document or presentation, eg typography, font, or layout. Lorem ipsum is mostly a part of a Latin text by the classical author and philosopher Cicero. Its words and letters have been changed by addition

is a pseudo-Latin text used in web design, typography, layout, and printing in place of English to emphasise design elements over content. It's also called placeholder (or filler) text. It's a convenient tool for mock-ups. It helps to outline the visual elements of a document or presentation, eg typography, font, or layout. Lorem ipsum is mostly a part of a Latin text by the classical author and philosopher Cicero. Its words and letters have been changed by addition



is a pseudo-Latin text used in web design, typography, layout, and printing in place of English to emphasise design elements over content. It's also called placeholder (or filler) text. It's a convenient tool for mock-ups. It helps to outline the visual elements of a document or presentation, eg typography, font, or layout. Lorem ipsum is mostly a part of a Latin text by the classical author and philosopher Cicero. Its words and letters have been changed by addition

is a pseudo-Latin text used in web design, typography, layout, and printing in place of English to emphasise design elements over content. It's also called placeholder (or filler) text. It's a convenient tool for mock-ups. It helps to outline the visual elements of a document or presentation, eg typography, font, or layout. Lorem ipsum is mostly a part of a Latin text by the classical author and philosopher Cicero. Its words and letters have been changed by addition





We work **+**
with the best
designers

Table Design

Tischdesign

The production process is based largely on manual craftsmanship, which is a significant asset for our original implementations. The Handicraft collection tables fit well into modern interiors and become the foreground items.

Unsere Produktion basiert mehrheitlich auf Handwerkskunst. Unsere Tische passen sich jeder Einrichtung an und bilden ein zentrales Objekt in jedem Raum.

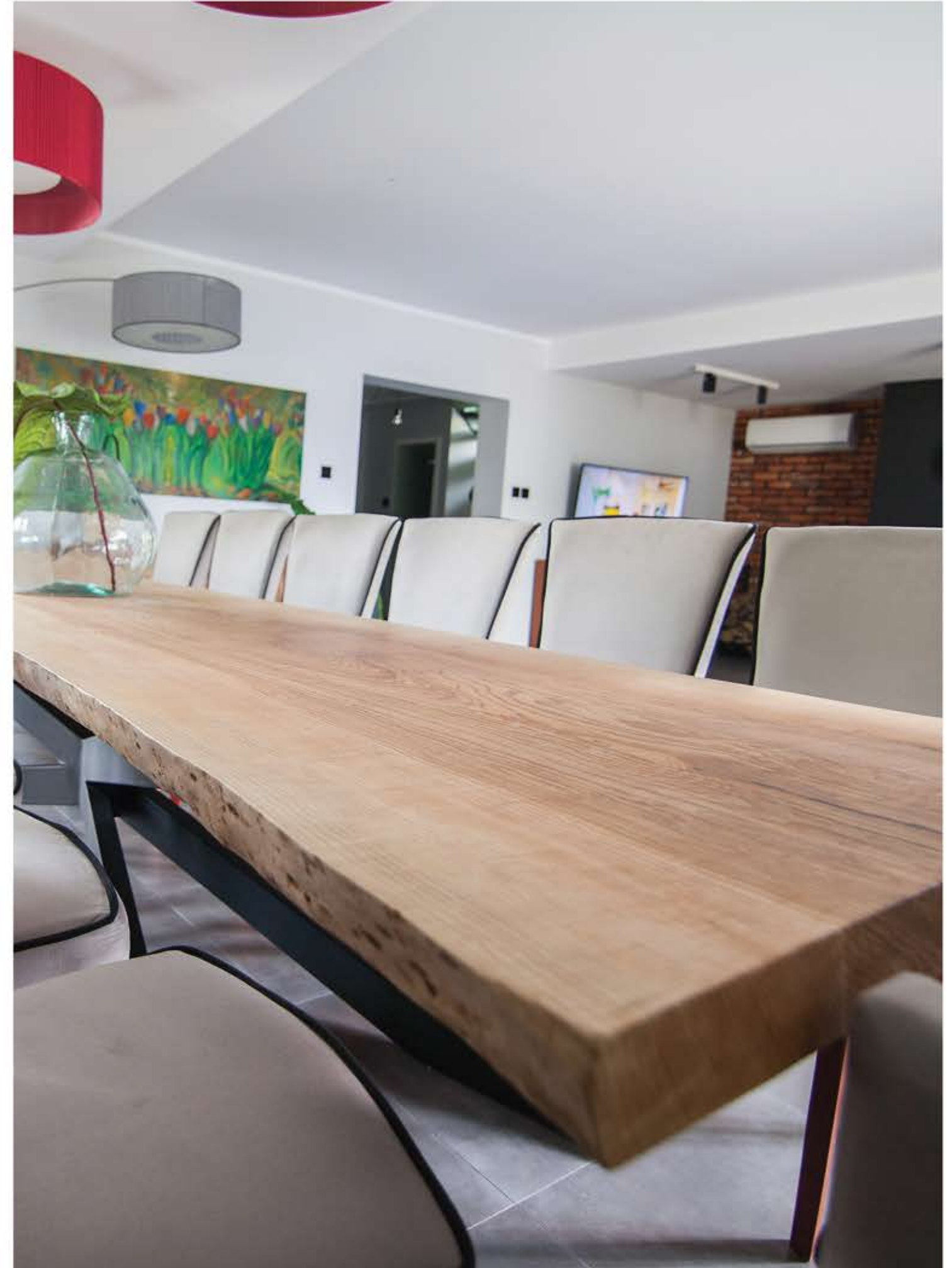

Extra Vagant

Extra Vagant – Die edle Struktur dieses Holzes stellt alles andere in den Hintergrund. Der dunkle Farbton gibt einen gewissen Kontrast in hellen Räumen wo graue und weiße Farbtöne dominieren.

Extra Vagant - a noble wood structure that distinguishes wood from the others. The dark colour contrasts well in bright and spacious interiors where grey and white predominate.



We do not rest on our laurels and constantly improve our products.

Wir ruhen niemals aus und sind bestrebt uns stets zu verbessern.



Style and elegance in a natural setting.
Stil und Eleganz in natürlicher Ausgabe.

IRREGULAR

For lovers of irregular edges, we have created the "Amber Beauty" collection. It is characterized by a unique amber wood structure. This product is in the form of a coffee table and a dining table.

Coffee table sizes: diameter 60-120cm, height: 35-60cm

Dining table sizes: diameter 100-200cm, height: 74cm

Für Liebhaber von naturgelassenen Produkten schufen wir unsere Kollektion „Amber Beauty“. Diese Kollektion charakterisiert sich mit einer einzigartigen Bernsteinstruktur des Holzes. Zur Kollektion gehören Produkte wie Kaffeetische und Esszimmertische.

Maße von Kaffeetischen: Durchmesser 60-120cm, Höhe: 35-60cm

Maße von Esszimmertischen: Durchmesser 100-200cm, Höhe: 74cm

AMBER beauty

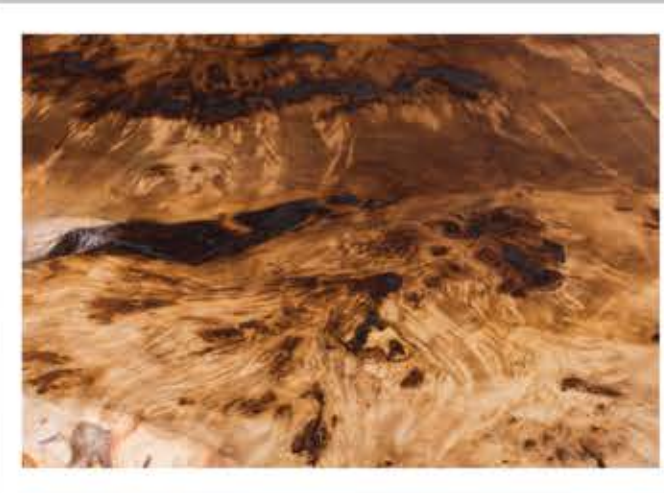

UNIQUE shape



looonger

Conference tables - Our conference tables are characterized by a unique appearance. Size is not an obstacle for us, the maximum length we are able to make is 8 meters from one board.

Konferenztische – Unsere Konferenztische charakterisieren sich mit einem einzigartigen Aussehen. Die Größe spielt bei uns keine Rolle da wir in der Lage sind Tische mit einer Länge von bis zu 8 Metern zu fertigen.



The Colorado model from the "Handicraft" collection was created in two versions. "Basic" version and "Basic Plus" version - with the possibility of adapting media ports. Standard available dimensions:
Length: 200-800cm
Depth: 90-130cm

Das Modell Colorado unserer Kollektion ist in 2 Versionen erhältlich, „Basic“ und „Basic Plus“ mit der Möglichkeit zur Adaption von Mediaanschlüssen.
Standardmaße:
Länge: 200-800cm
Tiefe: 90-130cm



SOFT DESIGN



unilateral

Monolith tables - A modern solid in traditional roots. Monoliths are always created of one type of wood. The original material (tree) for these types of tables must be unique and of considerable sizes. These trees have an incredible value for us that is why we make an effort to present their history preserving even the smallest symbols such as all kinds of cracks, growths and knots.

Holzbohlentische sind aus einem einzigen Baumstamm gefertigt. Bäume welche zu Tischen verarbeitet werden müssen eine gewisse Größe aufweisen und einzigartig sein. Unsere Tische sind für uns von hohem Wert, deswegen bemühen wir uns wertvolle Merkmale des Baumes hervorzuheben wie z.B. Risse, Knoten und Astansätze.

Gemäß dem aktuellen Trend zu Öko- und Naturprodukten, setzen wir auf Materialien aus Holz. Jedes unserer Möbelstücke ist ein Unikat, verarbeitet bis aufs kleinste Detail.



MONOLITH



STARDUST

Stardust table (black table, bleached) "Tell me gekalt" - this model was created for people who value the original appearance of the wood structure. The black and white colours create an original combination.

Sternenstaubtisch (schwarzer Tisch, gekalkt) Dieses Modell ist speziell für Menschen die die natürliche Struktur des Holzes wertschätzen. Die weißen und schwarzen Farbtöne schaffen eine originale Verbindung.



Monolith

We are always original
These tables require a lot of patience and precision, every even the smallest element must be properly prepared. Attention to detail and manual refinement of the smallest components makes these products have its own history and a soul.

We are always original -
Die Fertigung dieser Tische erfordert viel Geduld und Präzision. Jedes Einzelstück muss präzise vorbereitet werden. Mit äußerster Sorgfalt und Genauigkeit wird jedes Element vorbereitet.

Glass Virtuoso

Virtuoso
Glass

Handcrafts are becoming more and more exclusive, appreciative and desirable. Each of us dreams about making his home neat and elegant. "Handicraft" has in its collection a combination of wood and - resins.

Elegance and style - Combination of highly selected wood with a black resin conglomerate. Black colour gives the wood elegance. There are two models of Liquid Glass, high gloss and matte.

Handwerksarbeit ist immer gefragter. Jeder von uns wünscht sich dass unsere Einrichtung exklusiv und elegant aussieht. In unserer Produktauswahl finden sich Verbindungen von Holz und Baumharz.

Eleganz und Stil... - Die Vereinigung von ausgewähltem Holz und einem Gemisch aus schwarzem Baumharz. Der schwarze Farbton verleiht dem Holz Eleganz. Erhältlich in den Modellen liquide Glass und mate.



Blue – Water Edition "Blue River" - resembling a flowing river. This model combined unique wood shapes and many shades of blue, giving the impression of a rapid river.

Standard available dimensions:

Length: 140-350cm

Depth: 80-120cm

Blue – Water Edition „Blue River - Es erinnert an einen fließenden Fluss. Dieses Modell vereint einzigartige Baumformen mit blauen Nuancen wodurch es an einen reißenden Fluss erinnert.

Standardmaße:

Länge: 140-350cm

Tiefe: 80-120cm



I'am limited edition

The desk prototype was tested and improved, thanks to it we created a product which is solid, massive and delicate at the same time. Its construction is simple as well as ergonomic and practical for the customer as it is more comfortable to work on it.

The desk is available in 3 models.

Model "Basic" it's the basic version without drawers.

Model "Prime" it is equipped with two drawers.

Model "Prime Plus" it is the "Prime" model with additional partition in one of the drawers. Partitions are very practical because they help the user to keep everything in order; the most important items are within reach.

Der Prototyp unseres Schreibtisches wurde getestet und verbessert. Dadurch entstand ein solides, massives und gleichzeitig delikates Produkt. Seine Bauform ist einfach und ergonomisch sowie praktisch für jeden Nutzer, wodurch die Arbeit an diesem Schreibtisch sehr angenehm ist.

Der Schreibtisch ist erhältlich in 3 Versionen.

Die herkömmliche Version „Basic“ ist ohne Schubladen.

Die Version „Prime“ ist ausgestattet mit 2 Schubladen.

Die Version „Prime Plus“ enthält mehrere Fächer in einer Schublade. Die Fächer sind sehr praktisch da Sie für Ordnung sorgen und wichtige Sachen trotzdem immer in Reichweite sind.

SIZES / Größen

Dimensions:
Length: 80-280cm
Depth: 60,70cm
Height: 74cm

Maße:
Länge: 80-280cm
Tiefe: 60,70cm
Höhe: 74cm

Each model has a protective edge which prevents the documents or items from going down the desk. The entire desk was made of solid wood.

Jede Version enthält einen Sicherheitsrand welcher verhindert dass Unterlagen herunterfallen können.



Its natural structure is emphasized by numerous rings and knots.

Der Schreibtisch besteht aus einer Holzbohle. Seine natürliche Struktur ist gekennzeichnet durch Baumringe und Astansätze.



*Designed in our studio.
Projektiert in unserem Atelier.*

Classic

Tables "Traditional" - in our collection there is also a traditional, conservative table with straight edges. It is characterized by high simplicity and popularity. The "Traditional" table is also available in the "Traditional Plus" version.

Tische Traditional – Wir bieten auch herkömmliche, traditionelle Tische mit gerader Tischkante. Der Tisch wird auch in ausklappbarer Version angeboten als „Traditional Plus“.



Standard available dimensions:

Length: 150-400cm

Depth: 80-120cm

Maße:

Länge: 150-400cm

Tiefe: 80-120cm



MULTI tasking

MULTI TASKING ("Traditional Plus", "Innovative Plus") - a significant advantage of such a solution is having the usable floor area larger. The unusual unfolding of the table means that we do not have to observe the connections every day. Enlarging the table to the full size is very easy to assemble. The possibility to choose both straight and natural edges is also one of the pluses of this kind of table. Under the surface of the table there are mounted two invisible slides for everyday use which should be pulled out with additional part attached when one wants to unfold the table.

MULTI TASKING („Traditional Plus“, „Innovativ Plus“) – Der Vorteil des Besitzes einer solchen Lösung ist der, dass der es wenig Platz einnimmt. Ein weiterer ortteil ist dass der Tisch keine Stellen aufweist wo darauf zurückzuführen ist dass der Tisch aufklappbar ist. Der Tisch lässt sich sehr leicht ausklappen. Bei der Auswahl des Tisches kann man entscheiden ob die Tischkanten gerade sein sollen oder in Natur gehalten. Auf der Unterseite des Tisches sind Schienen montiert. Bei Bedarf den Tisch zu verlängern können diese Schienen herausgeschoben werden und die Zusatzteile können montiert werden.

Standard available dimensions:
Length: 150-400cm
Depth: 80-120cm

Standardmaße:
Länge: 150-400cm
Tiefe: 80-120cm

"Innovative" Tables - are the opposite of the "Traditional" model, characterized by natural unevenness of the side edges. The "Innovative" table is also available in the "Innovative Plus" version.

Tische Innovativ – das Gegenteil des Modells „Traditional“, charakterisiert sich mit naturgeformten Tischkanten. Das Modell „Innovativ“ ist auch als ausklappbare Version erhältlich als Modell „Innovativ Plus“.



Yourcolor Yourdesign

Many of us ordering a new item for our apartment do not want it to differ in colour from the rest of the decor. We offer a wide range of colours that is why we can adjust the colour of a new product to already existed items.

Viele von uns achten bei der Auswahl eines Möbels, dass es nicht von unseren anderen Möbeln farblich hervorsticht. In Anlehnung daran bieten wir eine Vielfalt von Farbtönen an damit Ihr Wunschprodukt an die Ihre anderen Möbel anpasst.



01



02



03



04



05



06



07



08



A001



A002



A003



A004



A005

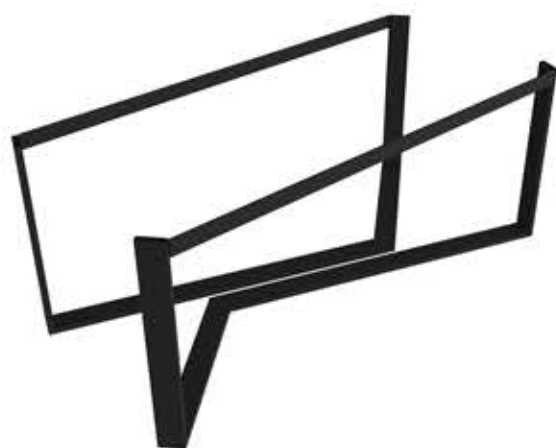

A006

choose your style

Legs available in our workshop are made of powder coated steel - the colour is optional. This form allows you to enjoy a long-lasting effect without your personal input. These models are available for standard orders but we can make an individual project on the customer's request. There is also a possibility to choose wooden legs, glass, chrome and stainless steel.

Each type of table is available with the following legs: square legs, spatial legs, trapezoidal legs, standard legs, Z legs, X legs.

Die Tischbeine aus unserem Atelier bestehen aus Stahl mit Pulverbeschichtung. Die Farbe ist auswählbar. Die Form garantiert jahrelange Freude am Produkt. Die Modelle sind bei Standardbestellungen erhältlich. Bei Kundenwunsch können wir ein individuelles Projekt fertigen. Zur Auswahl stehen auch Tischbeine aus Holz, Glas, Chrom oder Edelstahl.

Jeder Tisch ist mit folgenden Tischbeinformen erhältlich: Quadratbeine, Trapezbeine, Z-Beine, X-Beine oder Standardbeine.



Coffee Time



Coffee tables



"Small beauty" - they emphasize the climate of the entire room in an interesting way. During our production of the table you can feel not only the unusual aroma of coffee, but also a close contact with nature. They attract attention and are distinguished from standard products by their appearance.

Kaffetische- Small beauty- Auf eine interessante Weise unterstreichen diese Tische das Klima des Raumes. An diesem Tisch kann man nicht nur seinen Kaffee genießen, aber ebenso die intensive Nähe zur Natur. Mit seinem Aussehen ziehen diese Tische alle Blicke auf sich und unterscheiden sich von allem anderen.





Slices - these tables are characterized by an unusual shape. There are not two identical slices - each is unique

Pflastertische – Der große Unterschied dieser Tische ist die Form. Jeder Baumstammplaster ist anders und einzigartig.



WOOD MOOD

by Handicraft





**The
journey
begins
with wood**



Sinks Countertops - We are Wood - the wood in the bathroom has its value once again, it is timeless and always fashionable and nowadays when elegance and simplicity prevail, wood is the crowning of the whole room.

Tischplatte fürs Waschbecken – We are Wood - Holz im Bad ist wieder in der Mode. Holz verleiht jedem Bad eine gewisse Klasse.

**We Are
theWood**

Functionality in simplicity



ęczne rzemiosło jest coraz bardziej ekskluzywne, docenianie i pożądane. Każdy z nas marzy o tym, aby jego dom wyglądał schludnie i elegancko. W kolekcji „Handicraft” znalazło miejsce połączenie drewna i szkła - w ten sposób stworzyliśmy niety-

ęczne rzemiosło jest coraz bardziej ekskluzywne, docenianie i pożądane. Każdy z nas marzy o tym, aby jego dom wyglądał schludnie i elegancko. W kolekcji „Handicraft” znalazło miejsce połączenie drewna i szkła - w ten sposób stworzyliśmy nietypowe lustro.

ęczne rzemiosło jest coraz bardziej ekskluzywne, docenianie i pożądane. Każdy z nas marzy o tym, aby jego dom wyglądał schludnie i elegancko. W kolekcji „Handicraft” znalazło miejsce połączenie drewna i szkła - w ten sposób stworzyliśmy niety-

ęczne rzemiosło jest coraz bardziej ekskluzywne, docenianie i pożądane. Każdy z nas marzy o tym, aby jego dom wyglądał schludnie i elegancko. W kolekcji „Handicraft” znalazło miejsce połączenie drewna i szkła - w ten sposób stworzyliśmy niety-



I'm the ONE...

Amber beauty collection

Wooden sinks - a combination of wood and water always raises a lot of questions and controversy. We would like to dispel any doubts and ensure the extraordinary durability of this product. The surface is protected by high quality resin blends.

Holzwaschbecken – Die Verbindung von Holz und Wasser ist kontrovers und fraglich, jedoch möchten wir diese Zweifel zerstreuen und beweisen dass diese Verbindung es in sich hat. Die Oberfläche ist geschützt durch hochqualitativen Baumharz. Die Fertigung erfordert viel Geduld und Erfahrung.





Good Taste + Good Design = Successful

A restaurant is not only a place where we come to eat but also to meet and spend a nice time. Furniture does not have to be elegant but functional and durable. Our company always aspires to combine these two features. The original look combined with good cuisine means that customers are enjoyed to come back.

Restaurants sind nicht nur Orte wo wir unseren Hunger stillen, aber wo wir auch eine angenehme Zeit verbringen wollen. Die Einrichtung sollte daher nicht nur Elegant sein aber auch funktionell und beständig. Wir sind darauf bedacht diese Eigenschaften zu erfüllen wenn es um unsere Möbel geht. Ein originelles Aussehen in Verbindung mit gutem Essen sorgt dafür das Kunden gerne wiederkommen.

